

## Type 3003

Electrical rotary OPEN/CLOSE actuator  
Elektromotorischer Drehantrieb AUF/ZU  
Actionneurs électriques OUVERT/FERMÉ



## Operating Instructions

Bedienungsanleitung  
Manuel d'utilisation

We reserve the right to make technical changes without notice.  
Technische Änderungen vorbehalten.  
Sous réserve de modifications techniques.

© 2011 - 2016 Bürkert Werke GmbH

Operating Instructions 1601/02\_EU-ML\_00809466 / Original DE

<b>1. OPERATING INSTRUCTIONS .....</b>	<b>4</b>	7.3. Connecting the additional limit switches (optional) .....	13
1.1. Symbols.....	4	7.4. Circuit board for actuator with standard signal input .....	15
1.2. Definition of the term "device" .....	4	<b>8. ROTARY ACTUATORS WITH INTEGRATED EMERGENCY</b>	
<b>2. INTENDED USE.....</b>	<b>5</b>	<b>RESET .....</b>	<b>18</b>
2.1. Restrictions.....	5	8.1. Safety block for emergency power version .....	18
<b>3. GENERAL SAFETY INFORMATION.....</b>	<b>5</b>	8.2. Technical data .....	18
<b>4. GENERAL INFORMATION.....</b>	<b>7</b>	8.3. Electric wiring.....	19
4.1. Contact address.....	7	8.4. Circuit board .....	19
4.2. Warranty .....	7	<b>9. OPERATING.....</b>	<b>20</b>
4.3. Informations in the Internet.....	7	9.1. Safety information .....	20
<b>5. SYSTEM DESCRIPTION.....</b>	<b>7</b>	9.2. Manual operation of the rotary actuator .....	21
5.1. Intended area of application .....	7	9.3. Returning from manual to automatic operation .....	21
5.2. General description .....	7	<b>10. MAINTENANCE AND REPAIR.....</b>	<b>22</b>
5.3. Options.....	8	10.1. Safety information .....	22
5.4. Marking .....	8	10.2. Maintenance.....	22
5.5. Type label .....	8	10.3. Malfunctions .....	22
<b>6. TECHNICAL DATA.....</b>	<b>9</b>	<b>11. ACCESSORIES .....</b>	<b>23</b>
6.1. Conformity .....	9	<b>12. TRANSPORT, STORAGE, DISPOSAL .....</b>	<b>23</b>
6.2. Standards.....	9		
6.3. Operating conditions.....	9		
6.4. General technical data.....	9		
<b>7. INSTALLATION.....</b>	<b>13</b>		
7.1. Safety information .....	13		
7.2. Power and control connections .....	13		

## 1. OPERATING INSTRUCTIONS

The operating instructions describe the entire life cycle of the device. Keep these instructions in a location which is easily accessible to every user and make these instructions available to every new owner of the device.

### The operating instructions contain important safety information!

Failure to observe these instructions may result in hazardous situations.

- The operating instructions must be read and understood.

### 1.1. Symbols



#### **DANGER!**

##### **Warns of an immediate danger!**

- Failure to observe the warning may result in a fatal or serious injury.



#### **WARNING!**

##### **Warns of a potentially dangerous situation!**

- Failure to observe the warning may result in serious injuries or death.



#### **CAUTION!**

##### **Warns of a possible danger!**

- Failure to observe this warning may result in a moderately severe or minor injury.

#### **NOTE!**

##### **Warns of damage to property!**

- Failure to observe the warning may result in damage to the device or the equipment.



Designates additional significant information, tips and recommendations.



Refers to information in these operating instructions or in other documentation.

→ designates a procedure which you must carry out.

### 1.2. Definition of the term “device”

In these instructions, the term device always refers to the electrical rotary actuator Type 3003.

## 2. INTENDED USE

**Non-authorized use of the electrical rotary actuator Type 3003 may be dangerous to people, nearby equipment and the environment.**

- The device may be used outside.
- During use observe the authorized data, the operating conditions and conditions of use specified in the contract documents and in the operating instructions. These are described in the chapter entitled "Technical Data".
- The device may only be used in connection with third-party devices and components recommended or approved by Bürkert.
- Requirements for safe and proper operation are proper transport, storage and installation as well as careful operation and maintenance.
- Only use the device as intended.

### 2.1. Restrictions

Observe any existing restrictions that apply to the device to be exported.

## 3. GENERAL SAFETY INFORMATION

This safety information does not cover:

- Haphazard situations that can arise during installation, operation and maintenance of the use.
- Locally applicable safety regulations which the operator and installation personnel are obligated to follow.



### **Hazard due to electrical voltage!**

Intervention in the device poses an acute risk of injury.

- Before starting work, be sure to switch off the supply voltage and secure it to prevent restarting!
- Always connect **multiple electrical rotary OPEN/CLOSED actuators with phase isolation via a switch**.
- Observe all applicable accident protection and safety guidelines for electrical equipment!

**Unintentional operation or impermissible damage can lead to generally dangerous situations as well as physical injury!**

- Take appropriate measures to prevent the possibility of unintentional activation of the device!

**The general rules of technology apply to the planning and operation of the device!**

- Observe the general rules of technology!

### General hazardous situations.

To prevent injury, ensure:

- The electrical rotary actuator Type 3003 may not be used in potentially explosive atmospheres (in this case please use type 3004).
- Do not put any loads on the body (e.g. by placing objects on it or standing on it).
- Do not make any external modifications to the device body. Do not paint the body parts or screws.
- Do not install the actuator with the cover facing down (head first).
- When installing the actuator, observe a minimum distance of 30 cm to electromagnetic sources of interference.
- Installation and repair work may be carried out by authorized technicians only and with the appropriate tools.
- After an interruption in the power supply or pneumatic supply, ensure that the process is restarted in a defined or controlled manner.
- The device may be operated only when in perfect condition and in consideration of the operating instructions.
- The general rules of technology apply to application planning and operation of the device.

### NOTE!

#### Electrostatically sensitive components / modules!

The device contains electronic components that react sensitively to electrostatic discharge (ESD). Contact with electrostatically charged persons or objects will endanger these components. In the worst case, they will be immediately destroyed or will fail after commissioning.

- Observe the requirements according to EN 61340-5-1 in order to minimise or avoid the possibility of damage through sudden electrostatic discharge.
- You should also ensure that the electronic components do not come into contact with nearby operating voltage.

## 4. GENERAL INFORMATION

### 4.1. Contact address

#### Germany

Bürkert Fluid Control Systems  
Sales Center  
Christian-Bürkert-Str. 13-17  
D-74653 Ingelfingen  
Tel. + 49 (0) 7940 - 10-91 111  
Fax + 49 (0) 7940 - 10-91 448  
E-mail: [info@de.buerkert.com](mailto:info@de.buerkert.com)

#### International

Contact addresses are found on the final pages of this operating manual.

And also on the Internet under: [www.burkert.com](http://www.burkert.com)

### 4.2. Warranty

The warranty is only valid if the electromotive rotary actuator type 3003 is used as intended in accordance with the specified application conditions.

### 4.3. Informations in the Internet

The operating manual and the data sheets on Type 3003 can be found on the Internet under: [www.burkert.com](http://www.burkert.com)

## 5. SYSTEM DESCRIPTION

### 5.1. Intended area of application

The electrical rotary OPEN/CLOSED actuator type 3003 (referred to as rotary actuator in the following) is designed for ball or flap valves.

### 5.2. General description

Due to its modular construction, the basic device can be extended with many options.



Options for expanding the basis device are found in chapter "5.3. Options".

The rotary actuator is designed for direct or alternating current with a varied rating and available for torques of 20, 35, 60 or 100 Nm. The materials used guarantee maintenance-free operation and ensure a low thermal load.

All rotary actuators are equipped with a standard emergency manual control and two additional limit switches and are tested by the manufacturer. The limit switches are set for a 0 ... 90° operating range.

### 5.3. Options

- Additional limit switches
- Rotary actuator with feedback potentiometer:
  - Potentiometer with resistance values of 100 Ω, 1 kΩ, 5 kΩ, 10 kΩ
  - Analogue feedback via 4 ... 20 mA signal
- 3rd position (180°)
- Actuators with integrated fail safe function (see chapter "8. Rotary actuators with integrated emergency reset")

### 5.4. Marking

The rotary actuator is fitted with a type label which enables clear identification and provides the most important technical data.



Do not remove the type label from the rotary actuator!  
It is extremely important for identification during installation and maintenance.  
The warranty is void without the type label.

### 5.5. Type label

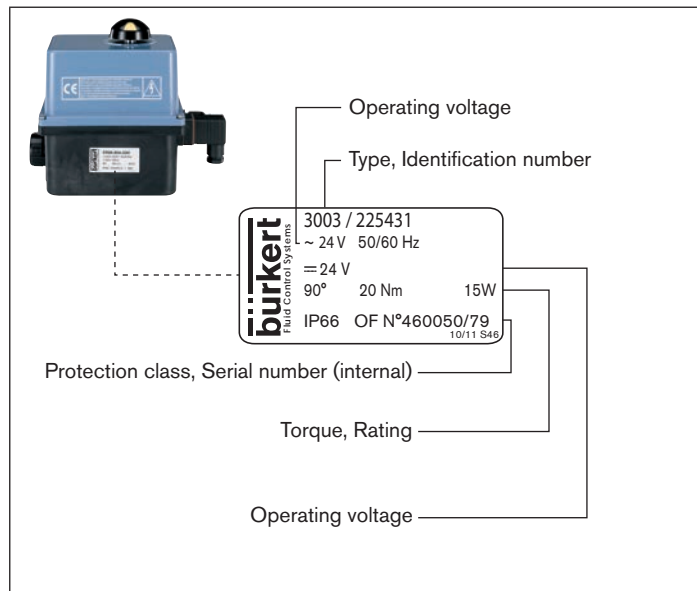

Fig. 1: Location and description of the type label



## 6. TECHNICAL DATA

### 6.1. Conformity

In accordance with the EC Declaration of conformity, the electromotive rotary actuator type 3003 is compliant with the EC Directives.

### 6.2. Standards

The applied standards, which verify conformity with the EC Directives, can be found on the EC Type Examination Certificate and/or the EC Declaration of Conformity.

### 6.3. Operating conditions

Ambient temperature:	-10 °C ... +55 °C -10 °C ... +40 °C (Emergency reset)
Permissible areas of application:	0 ... 2000 m altitude
Permissible humidity:	< 81 % to 31 °C (88 °F) with linear decrease as far as 50 % at 40 °C (according to EN 61010-1)
Protection class:	IP66 with cable bushing

### 6.4. General technical data

#### 6.4.1. Mechanical data

Dimensions:	See data sheet
Weight:	1.3 kg (20 Nm) 2.8 - 3.1 kg (35-100 Nm)

#### Materials

Cover:	Nylon
Body:	PA (Nylon with glass fibre)
Axis / screws:	Stainless steel
Gears:	Stainless steel and PC (Polycarbonate)
Actuating angle:	90° ± 5° (optional 180°, 270°)
Duty cycle:	50 % at max. torque

#### 6.4.2. Electrical data

Electrical connections:	Cable bushing according to EN 175301-803 Cable gland ISO M20
Limit switches:	4 adjustable (2 for the motor and 2 additional ones for feedback signal) - max. 250 V AC / 5 A

**Electrical data for version without analog input signal:**

Torque	90° Positioning time <sup>1)</sup> (Specifications under load)	Power consumption	Voltage / Frequency
20	12 s	15 W	15-30 V AC, 50-60 Hz / 12-48 V DC <sup>2)</sup>
			100-240 V AC, 50-60 Hz / 100-350 V DC
35	7 s	45 W	15-30 V AC, 50-60 Hz / 12-48 V DC <sup>2)</sup>
			100-240 V AC, 50-60 Hz / 100-350 V DC
60	12 s	45 W	15-30 V AC, 50-60 Hz / 12-48 V DC <sup>2)</sup>
			100-240 V AC, 50-60 Hz / 100-350 V DC
100	23 s	45 W	15-30 V AC, 50-60 Hz / 12-48 V DC <sup>2)</sup>
			100-240 V AC, 50-60 Hz / 100-350 V DC

<sup>1)</sup> Other positioning times on request

<sup>2)</sup> The operating voltage must not drop below 11.5 V



We recommend an actuator designed with 1.5 times the maximum torque of the fitting (On/Off).

**Electrical data for version with analog input signal:**

Torque	90° Positioning time <sup>1)</sup> (Specifications under load)	Power consumption	Voltage / Frequency
20	25 s	15 W	15-30 V AC, 50-60 Hz / 12-48 V DC <sup>2)</sup>
			100-240 V AC, 50-60 Hz / 100-350 V DC
35	40 s	45 W	15-30 V AC, 50-60 Hz / 12-48 V DC <sup>2)</sup>
			100-240 V AC, 50-60 Hz / 100-350 V DC
60	79 s	45 W	15-30 V AC, 50-60 Hz / 12-48 V DC <sup>2)</sup>
			100-240 V AC, 50-60 Hz / 100-350 V DC
100	119 s	45 W	15-30 V AC, 50-60 Hz / 12-48 V DC <sup>2)</sup>
			100-240 V AC, 50-60 Hz / 100-350 V DC

<sup>1)</sup> Other positioning times on request

<sup>2)</sup> The operating voltage must not drop below 11.5 V



We recommend an actuator designed with 2 times the maximum torque of the fitting (analog input signal).

### 6.4.3. Electrical circuit diagrams

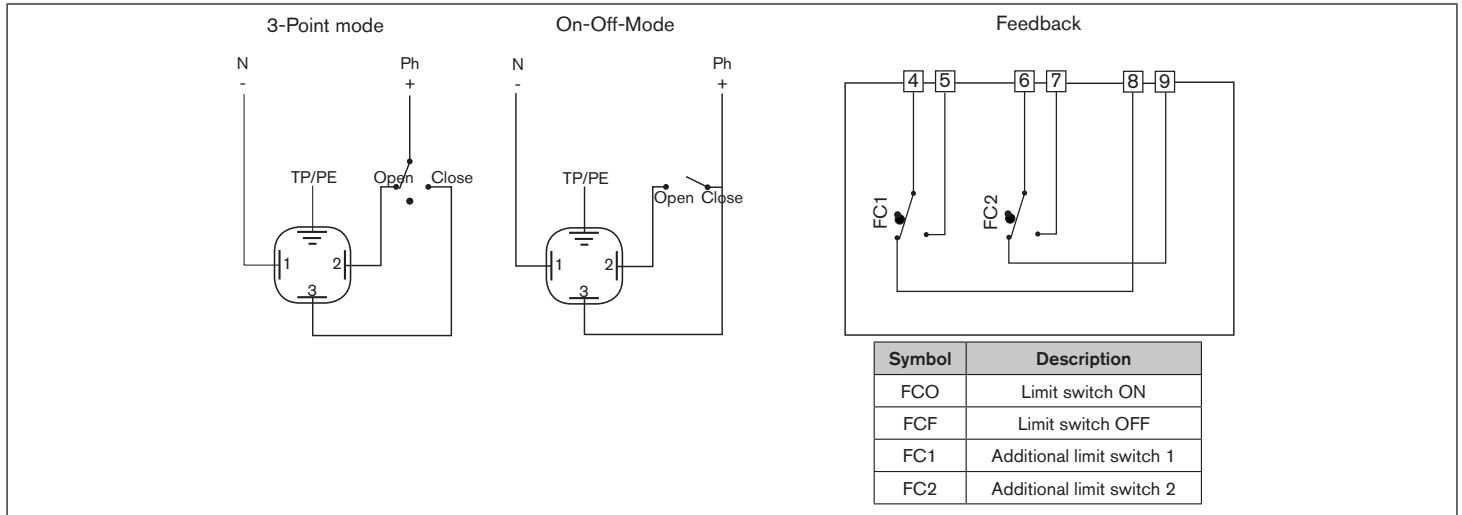

Fig. 2: Open/Closed Version



If voltage is applied simultaneously to terminals 2 and 3, terminal 2 is the leading one and the actuator moves to the OPEN position.

#### NOTE!

Make certain in 3-point mode that the pulse duration of a controller lasts for at least 1 second. A pause time of at least 500 ms is required before controller activation is repeated. Observe the duty cycle specified on the type label!

Please note the circuit board must remain power supplied to allow heating resistances working.

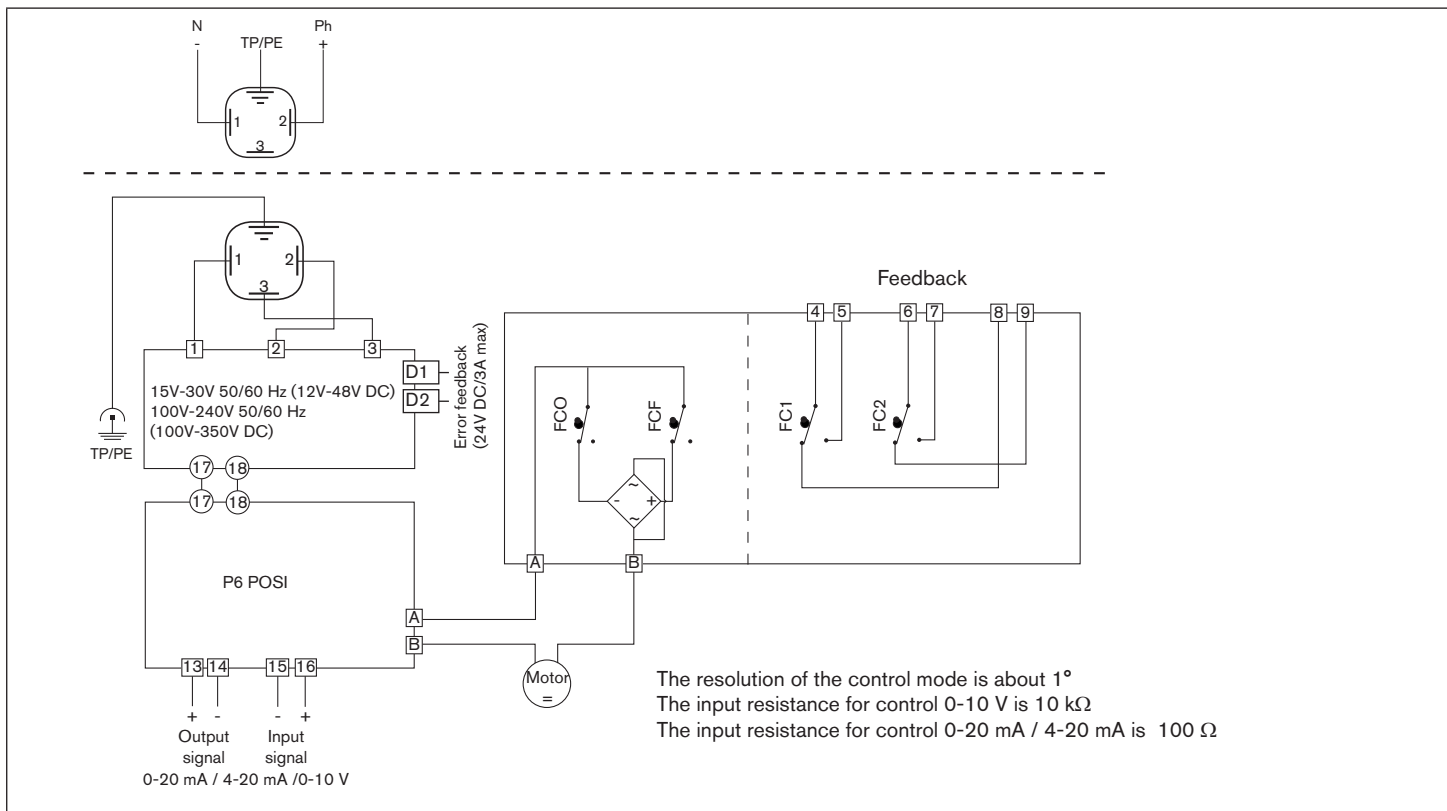

Fig. 3: Version with analog input signal

## 7. INSTALLATION

### 7.1. Safety information



#### **DANGER!**

##### **Hazard due to electrical voltage!**

- Always switch off the power and secure it to prevent restarting before removing the cover, or using the lever.
- Always connect multiple rotary actuators with phase isolation via a switch!
- Protect electrical rotary actuators by using a mains-dependent safety!
- Observe all applicable accident protection and safety guidelines for electrical equipment!



#### **WARNING!**

##### **Hazard due to improper installation!**

- Installation may only be carried out by authorised technicians using appropriate tools!
- Before installation, ensure that the manual lever can move freely.

##### **Danger due to unintentional activation of the device!**

Unintended actuation of the device during installation can lead to injury and damage to property.

- Take appropriate measures to prevent the possibility of unintentional activation of the device.

### 7.2. Power and control connections

#### **Procedure:**

- Disconnect the rotary actuator from the power supply.
- Remove the position indicator from the axis.
- Loosen the cover screws with a screwdriver and lift the cover off.
- Disconnect the cable connector ISO20 and insert the cable.
- Wire the connections according to the circuit diagram figures (see [“6.4.3. Electrical circuit diagrams”](#)).



Use cables with a diameter of 7 ... 12 mm for the ISO20 cable fitting.

- Set the cover in place and screw it tight.
- Reinstall the position indicator.

### 7.3. Connecting the additional limit switches (optional)

In the standard variant, the rotary actuator has 2 additional limit switches (for 90° range of motion). Connect these as follows.

#### **Procedure:**

- Disconnect the rotary actuator from the power supply.
- Remove the position indicator from the axis.
- Use a screwdriver to loosen the cover screws.

- Lift the cover off.
- Wire the connections of the additional limit switches (FC1 and FC2) according to the circuit diagram figures (see “Fig. 2” and “Fig. 3”).
- Tighten the cable gland after connecting the terminals.
- Set the cover in place and screw it tight.
- Reinstall the position indicator.



Only use 4 or 6 conductor cable with a diameter of 7 ... 12 mm for the ISO20 cable fitting.

Ensure that the cable in the ISO20 cable fitting is completely sealed when tightening the union nut.

### 7.3.1. Setting the limit switches



The rotary actuator is supplied with the following factory settings:

- The CLOSED limit switches are activated with the cams 2 and 4 (closed position).
- The OPEN limit switches are preset at a 90° rotation angle.

The procedure for setting the limit switches is shown in “Fig. 4” and “Fig. 5”.

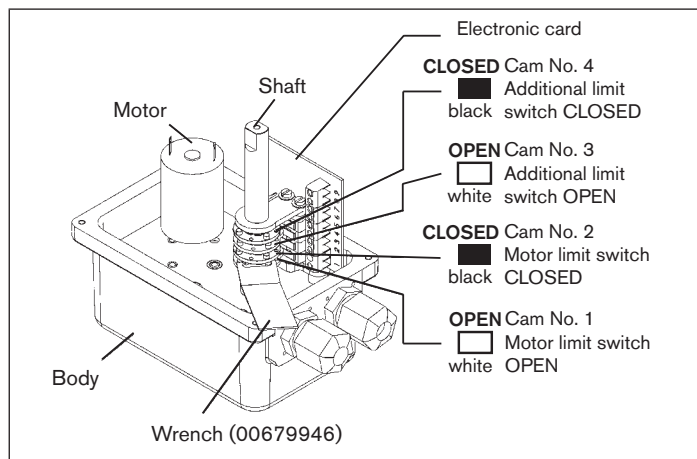

Fig. 4: Setting the limit switches. Limit switches max. 250 V / 5 A

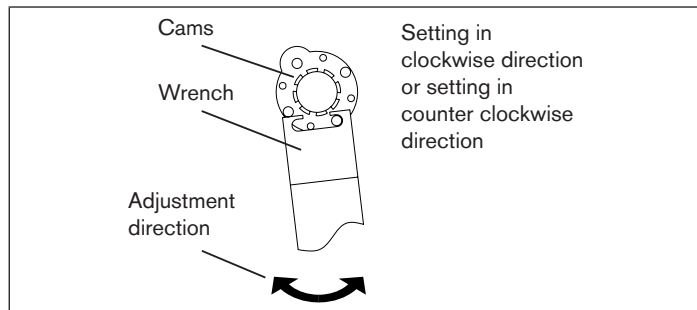

Fig. 5: Setting limit switches in counter clockwise and clockwise directions

## 7.4. Circuit board for actuator with standard signal input

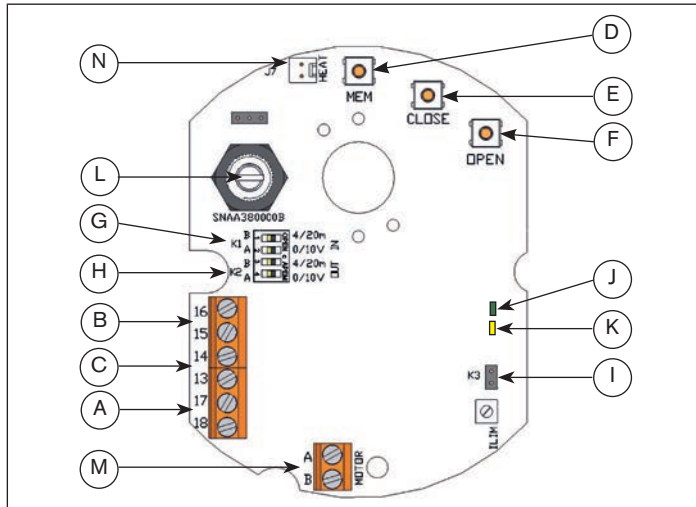

Fig. 6: Circuit board

A	Electrical power supply 24 V AC/DC	H	K2 plug-in jumper
B	Connection terminals of the input signal	I	K3 plug-in jumper
C	Connection terminals of the feedback	J	Green and red LED

D	MEM pushbutton	K	LED yellow: Indicates the power supply
E	CLOSE pushbutton	L	Potentiometer
F	OPEN pushbutton	M	Motor connection
G	K1 plug-in jumper	N	Heat resistor connection



To prevent electromagnetic interference, shielded cables must be used.

### Procedure:

- Loosen the cable gland and feed the cable through.
- Wire the signal transducer between terminals 15 and 16. Terminal 15 is the negative pole (-) and terminal 16 the positive pole (+).
- Wire the position feedback sensor between terminals 13 and 14. Terminal 13 is the positive pole (+) and terminal 14 the negative pole (-).
- Re-attach the cable gland.



If the connection voltage is 100 V to 240 V, a fuse must be provided in the power supply.

### 7.4.1. Specify position of the plug-in jumpers

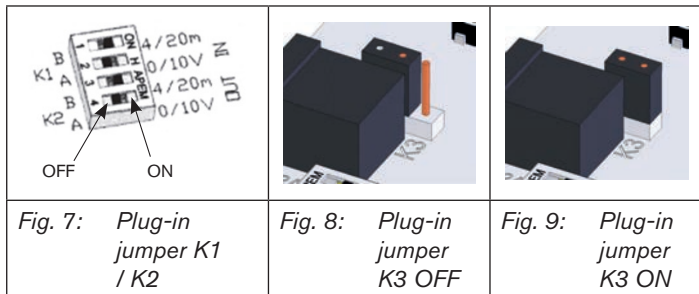

Fig. 7: Plug-in jumper K1 / K2

Fig. 8: Plug-in jumper K3 OFF

Fig. 9: Plug-in jumper K3 ON

Signal transducer	Feed-back	Plug-in jumper K1		Plug-in jumper K2		Plug-in jumper K3
		A	B	A	B	
0-10 V	0-10 V	ON	OFF	ON	OFF	OFF
0-10 V	0-20 mA	ON	OFF	OFF	ON	OFF
0-10 V	4-20 mA	ON	OFF	OFF	ON	ON
0-20 mA	0-10 V	OFF	ON	ON	OFF	OFF
0-20 mA	0-20 mA	OFF	ON	OFF	ON	OFF
0-20 mA	4-20 mA	OFF	ON	OFF	ON	ON
4-20 mA	0-10 V	OFF	ON	ON	OFF	OFF
4-20 mA	0-20 mA	OFF	ON	OFF	ON	OFF
4-20 mA	4-20 mA	OFF	ON	OFF	ON	ON

### 7.4.2. Parameterization steps

#### Specify direction of rotation of the shut-off valve

**Normal direction of rotation (preset)**

→ Press <OPEN> pushbutton and switch on the card (hold down pushbutton).  
The GREEN LED lights up.  
→ Release <OPEN> pushbutton and disconnect the card from the power supply.

**Reverse direction of rotation**

→ Press <CLOSE> pushbutton and switch on the card (hold down pushbutton).  
The RED LED lights up.  
→ Release <CLOSE> pushbutton and disconnect the card from the power supply.

#### Specify control signal type

**Control signal when voltage 0 – 10 V**

→ Press <MEM> pushbutton and switch on the card (hold down pushbutton).  
The RED LED lights up **3x**.  
→ Release <MEM> pushbutton and disconnect the card from the power supply.



## Type 3003

### Installation

#### Control signal when current 0 – 20 mA

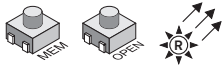

- Press <MEM> and <OPEN> pushbutton and switch on the card (hold down pushbutton).  
The RED LED lights up **3x**.
- Release <MEM> and <OPEN> pushbutton and disconnect the card from the power supply.

#### Control signal when current 4 – 20 mA (preset)

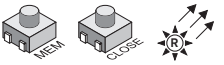

- Press <MEM> and <CLOSE> pushbutton and switch on the card (hold down pushbutton).  
The RED LED lights up **3x**.
- Release <MEM> and <CLOSE> pushbutton and disconnect the card from the power supply.

#### Learning mode

##### Specify end positions



- Press <OPEN> and <CLOSE> pushbutton and switch on the card (hold down pushbutton).  
The RED and the GREEN LEDs light up.
- Release <OPEN> and <CLOSE> pushbutton.  
Both LEDs go out.  
Learning mode is selected.



- Press <CLOSE> pushbutton to move the shut-off valve into the closed position.  
The RED LED lights up.

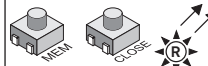

- Press <MEM> and <CLOSE> pushbutton to save the closed position.  
The RED LED lights up **2x**.





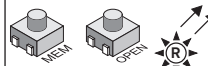



- Press <OPEN> pushbutton to move the shut-off valve into the open position.  
The GREEN LED lights up.



- Press <MEM> and <OPEN> pushbutton to save the open position.  
The GREEN LED lights up **2x**.

Specify end positions	
	All positions are now saved. → Disconnect the card from the power supply.

### 7.4.3. Normal operation

Display normal operation	
	→ Switch on card. The GREEN LED lights up <b>3x</b> to indicate that the start process has been implemented correctly.
	In normal operation the GREEN LED lights up when the rotary actuator opens the shut-off valve.
	The RED LED lights up when the rotary actuator closes the shut-off valve.
 	If neither of the LEDs is lit, the actuator is not actuated.
 	The RED and the GREEN LEDs light up if the torque is too high and the rotary actuator stops. → Change direction of rotation of the rotary actuator or switch over the voltage OPEN/ CLOSED to restart the rotary actuator!

## 8. ROTARY ACTUATORS WITH INTEGRATED EMERGENCY RESET

### 8.1. Safety block for emergency power version

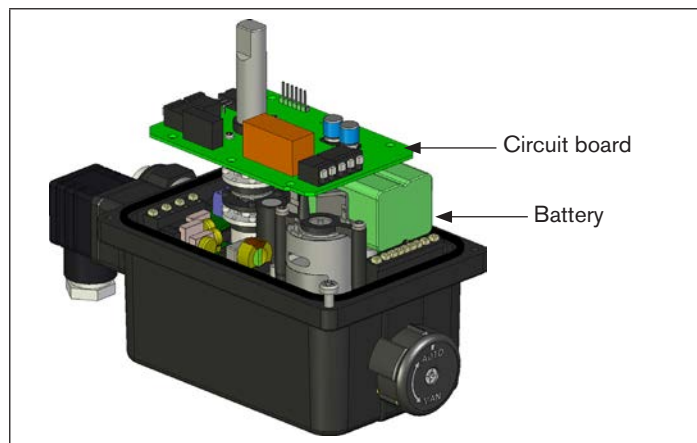

Fig. 10: Safety block for emergency power version

### 8.2. Technical data

Voltage: 18 V DC

Current nominal: 0.8 A

## Type 3003

Rotary actuators with integrated emergency reset

Max. current	2.4 A
Charging time	14 h max
Feedback relay for charge state	24 V DC - 1 A max
Permitted ambient temperature	-10 °C - +40 °C

### 8.3. Electric wiring

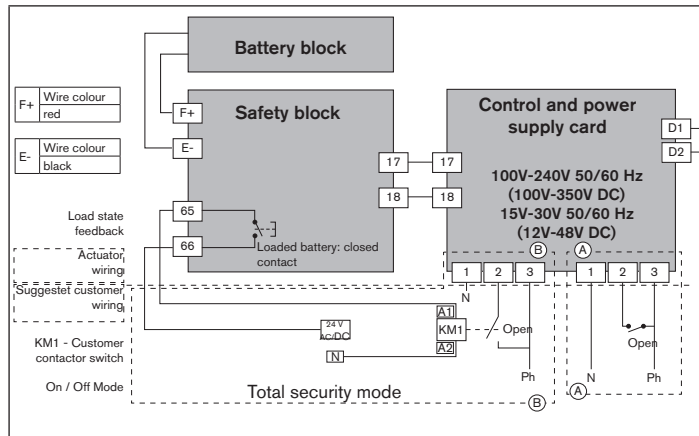

Fig. 11: Electric wiring

#### Configuration A or B

A-standard mode: If the actuator is controlled with a programmable controller, the feedback of the charge state can be connected to it.

B-mode - increased safety (if the feedback relay is used, terminals 65 and 66): The actuator does not actuate the valve unless the safety block is loaded.

### 8.4. Circuit board

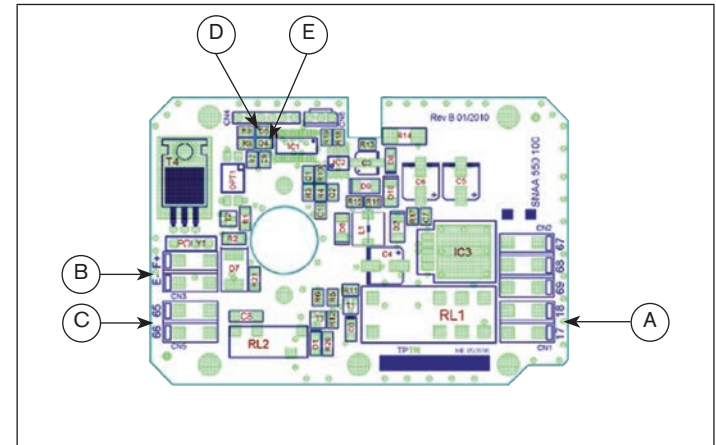

Fig. 12: Diagram: Circuit board

A	18 V DC connection
B	Battery block connection
C	Connection for feedback (charge state)

D	Green LED*
E	Red LED **

Description of the LED:

Green LED	Red LED	Description
Off	Blinks / Off / Blinks	Battery off or out of service
On	Blinks	Battery loading cycle in progress (max. 14 h)
On	Off	Battery loading cycle finished
Blinks rapidly	Off	Actuator electrical supply during 3 min. (failure mode)
Off	Blinks rapidly	Microcontroller failure

## 9. OPERATING

### 9.1. Safety information



#### **DANGER!**

**Hazard due to electrical voltage!**

**Intervention in the device poses an acute risk of injury.**

- Turn off the power before manually servicing the rotary actuator.



#### **WARNING!**

**Hazard due to improper servicing!**

Improper servicing can result in personal injury and in damage to the device and its surroundings.

- The operating personnel must be aware of and fully understand the operating instructions.
- Pay attention in particular to the safety information and the intended use.
- The device may only be serviced by properly trained personnel.

**Hazardous situation due to manual intervention!**

During manual intervention the process can change into an undefined state which can lead to hazardous situations.

- Ensure a defined and controlled restarting of the process following manual intervention!

## 9.2. Manual operation of the rotary actuator

The rotary actuator can be operated manually if there is a power failure. To do this, the handwheel must be turned to „MAN“ (see [“Fig. 13”](#)).

### Procedure:

- During manual operation ensure that the rotary actuator is not activated in automatic mode.
- Remove the position indicator from the axle.
- Turn the handwheel from “AUTO” to “MAN”.
- Using a wrench, turn the actuator shaft into the required position. In doing so, hold the handwheel.

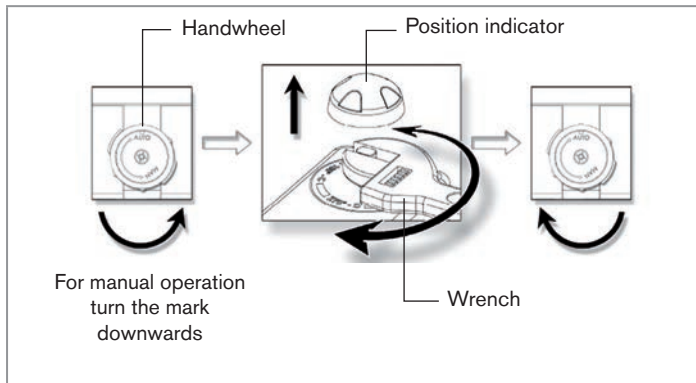

Fig. 13: Switching the rotary actuator from automatic to manual operation

## 9.3. Returning from manual to automatic operation

Returning to automatic operation:

- Let go of the handwheel to switch back into automatic operation. The spring force automatically resets it to the „AUTO“ position.
- Replace the position indicator. The marking should now show the set position.

## 10. MAINTENANCE AND REPAIR

### 10.1. Safety information



#### WARNING!

##### Hazard due to improper maintenance!

- Installation and maintenance work may only be carried out by authorised technicians using appropriate tools!

##### Danger due to unintentional activation of the system!

Unintended actuation of the system during maintenance and repair work can lead to injury and damage to property.

- Take appropriate measures to prevent the possibility of unintentional activation of the system.

### 10.2. Maintenance

The rotary actuator is maintenance-free when used in a manner corresponding to the instructions in this manual.

### 10.3. Malfunctions

Malfunctions	Resolution
The rotary actuator does not function (first commissioning)	Check power supply
	Check the connections against the circuit diagram included

Malfunctions	Resolution
The rotary actuator is stuck in the OPEN position	Check power supply
	Check the connections against the circuit diagram included
	Check whether the movement of the electrical valve is obstructed
The valve does not open or close completely	Check power supply
	Check the connections against the circuit diagram included
	Check the limit switches
	Check whether there is any overload due to too-high torque on the valve (our rotary actuators are equipped with thermostats)
	<b>If yes:</b> interrupt power for 5 minutes
The rotary actuator is stuck in the CLOSED position	Check power supply
	Check the connections against the circuit diagram included
	Check whether the movement of the electrical valve is obstructed

## 11. ACCESSORIES



### CAUTION!

#### Risk of injury and/or damage by the use of incorrect parts!

Incorrect accessories and unsuitable replacement parts may cause injuries and damage the device and the surrounding area.

- Use only original accessories and original spare parts supplied by Bürkert.

Designation	Order no.
Key for adjusting the limit switches	679 946
Reducing sleeve star/square 14/9 mm	665 288
Reducing sleeve star/square 14/11 mm	665 289
Reducing sleeve star/star 22/14 mm	666 684
Reducing sleeve star/square 22/17 mm	684 858
Reducing sleeve square/square 17/14 mm	665 290
Adapter outer square 14/10 mm	668 234
Position indicator 20 Nm	679 722
Position indicator > 20 Nm	679 723

## 12. TRANSPORT, STORAGE, DISPOSAL

### NOTE!

#### Transport damages!

Inadequately protected equipment may be damaged during transport.

- During transportation protect the device against wet and dirt in shock-resistant packaging.
- Avoid exceeding or dropping below the permitted storage temperature.

#### Incorrect storage may damage the device.

- Store the device in a dry and dust-free location!
- Storage temperature. -10 ... +55 °C.

#### Damage to the environment caused by device components contaminated with media.

- Dispose of the device and packaging in an environmentally friendly manner.
- Observe applicable regulations on disposal and the environment.
- Observe national waste disposal regulations.

[www.burkert.com](http://www.burkert.com)